

EX36 Corner-mount No-grip Camera

www.boschsecurity.com



BOSCH
Invented for life



- ▶ Patented No-Grip anchor-free design
- ▶ Perfectly flush fit into corners
- ▶ Complete coverage of a 4.5 x 4.5 m (15 x 15 ft) room
- ▶ Designed for maximum safety
- ▶ Compact, tamper- and vandal-resistant

The EX36 is a vandal-resistant corner camera featuring anchor-free No-Grip design. The EX36 has no anchor points for maximum safety in environments with at-risk individuals. The innovative design allows a perfectly flush fit into the corner of a room that protects against even the most brutal attempt to destroy, detach or disable the camera. The sharp 45° angle hides all wiring and delivers complete coverage of the entirety of a 4.5 x 4.5 m (15 x 15 ft) room, including below the camera itself. Available with optional microphone.

Functions

Applications

- Prison cells
- Hospital recovery rooms
- Psychiatric care rooms
- Vandal-prone areas
- Sleep research

Certifications and approvals

CSA C22.2 No 0-M1991	General Elec. Rqts, Part II
CSA C22.2 No 1-M94	Audio, Video and Similar Equip.
CSA C22.2 No 94-M91	Special Purpose Enclosures
UL Std No 50	Enclosures for Elec. Equipment

UL Std No 2044

Commercial CCTV Equipment

FCC PART 15 Class A

Region	Certification
Europe	CE

Installation/configuration notes

Dimensions

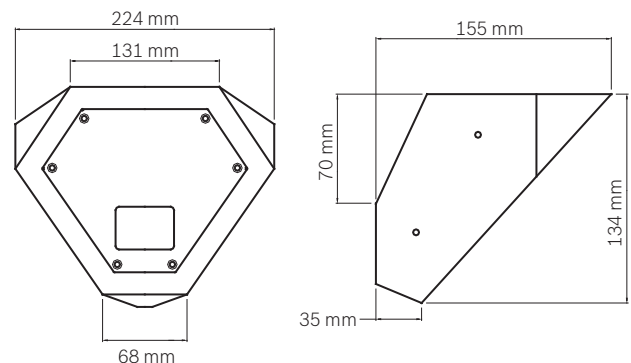

Technical specifications

Color Cameras

CCD	C7 High Resolution Color
Image Sensor	1/3 in Interline SuperHAD
Resolution	500 TVL
Effective Pixels	NTSC: 768 x 494 (HxV) PAL: 752 x 582 (HxV)
Sensitivity	2.7 lux at F1.4
S/N Ratio	Greater than 48 dB

All Versions

Video Output	1 Vpp, 75 ohm
Electronics Iris	1/60 to 1/100,000 (NTSC) 1/50 to 1/100,000 (PAL)
Voltage Supply	12 to 24 VAC or VDC
Power Consumption	120 mA at 12 VDC, 1.4 W (max)
Dome Construction	Steel / Painted flush removable front panel with security screws
Window	1/4 in LEXAN
Dimensions	224 x 134 x 155 mm 8.8 x 5.3 x 6.1 in
Weight	0.61 kg (1.3lb)
Operation Temperature Range	-50 °C to +50 °C (-58 °F to 122 °F)
Microphone Frequency Response	20 Hz to 10 kHz
Microphone Sensitivity	68 dB +/-3 dB
Microphone Output	3.2 Vpp / 750 Ohm; bare leads

Ordering information

EX36C702W-N Corner-mount No-grip Camera

1/3 in. hi-res color, 500TVL, NTSC
Order number **EX36C702W-N**

EX36C702W-P Corner-mount No-grip Camera

1/3 in. hi-res color, 500TVL, PAL
Order number **EX36C702W-P**

EX36C702WM-N Corner-mount No-grip Camera

1/3 in. hi-res color, 500TVL, NTSC, microphone
Order number **EX36C702WM-N**

EX36C702WM-P Corner-mount No-grip Camera

1/3 in. hi-res color, 500TVL, PAL, microphone
Order number **EX36C702WM-P**

Accessories

UPA-2430-60 Power Supply

120 VAC, 60 Hz, 24 VAC, 30 VA Out
Order number **UPA-2430-60**

UPA-2420-50 Power Supply

220 VAC, 50 Hz, 24 VAC, 20 VA Out
Order number **UPA-2420-50**

PSU-124-DC050 Universal Power Supply

Universal Outdoor Power Supply, 120 to 240 VAC, 50/60 Hz In; 24 VDC, 50 W Out
Order number **PSU-124-DC050**

Represented by:

Americas:

Bosch Security Systems, Inc.
130 Perinton Parkway
Fairport, New York, 14450, USA
Phone: +1 800 289 0096
Fax: +1 585 223 9180
security.sales@us.bosch.com
www.boschsecurity.us

Europe, Middle East, Africa:

Bosch Security Systems B.V.
P.O. Box 80002
5617 BA Eindhoven, The Netherlands
Phone: + 31 40 2577 284
Fax: +31 40 2577 330
emea.securitysystems@bosch.com
www.boschsecurity.com

Asia-Pacific:

Robert Bosch (SEA) Pte Ltd, Security
Systems
11 Bishan Street 21
Singapore 573943
Phone: +65 6571 2808
Fax: +65 6571 2699
apr.securitysystems@bosch.com
www.boschsecurity.asia

China:

Bosch (Shanghai) Security Systems Ltd.
201 Building, No. 333 Fuquan Road
North IBP
Changning District, Shanghai
200335 China
Phone +86 21 22181111
Fax: +86 21 22182398
www.boschsecurity.com.cn

America Latina:

Robert Bosch Ltda Security Systems Division
Via Anhanguera, Km 98
CEP 13065-900
Campinas, Sao Paulo, Brazil
Phone: +55 19 2103 2860
Fax: +55 19 2103 2862
latam.boschsecurity@bosch.com
www.boschsecurity.com