

# DDF4920HDV-DN

HD Dome Camera, 5-Megapixel, Full High-Definition, 1080p/30, H.264, Day/Night (ICR), Remote Back Focus Control with One-Push Autofocus, PoE (Class 0), Vandal-resistant (IK10)



The DDF4920HDV-DN is a **5-megapixel HD network camera** built into a **vandal-resistant (IK10) dome enclosure**.

The camera provides **real-time Full HD video (1080p/30)** using the **H.264** codec, currently, the most advanced standard for **high-efficiency video compression** and supports **resolutions up to 5-megapixel**.

Besides a comprehensive set of automatic and manual image optimization functions and many other setting options, it features automatic **Day/Night** operation supported by integrated **ambient light sensing** and a **removable IR cut filter (ICR<sup>1)</sup>**.

The built-in **Remote Back Focus Control** technology allows for a **precise and easy remote focusing over the network**. With just one click, first the almost ideal focus range is recognized automatically (**One-Push Autofocus**), which then can be precisely adjusted by using manual fine-tuning, if needed, in order to always get perfect images with excellent sharpness.

In conjunction with the **Digital Image Shift** function, which provides for a **subsequent digital fine alignment of the image section**, a convenient and straightforward installation process of the camera is guaranteed.

Depending on the requirements, the camera can be conventionally supplied with 12V DC or conveniently operated via **Power over Ethernet** (PoE Class 0, IEEE 802.3af) which allows for an easy, quick and cost-effective cabling and commissioning.

## Features

- 1/2.5" 5-megapixel CMOS image sensor
- Pure Digital Signal Processing
- Real-time Full HD video (1080p/30)
- Automatic Day/Night switching using ambient light sensing and ICR<sup>1)</sup> function (switching threshold level adjustable)
- High light sensitivity (0,3lux at F1.0, 50IRE)
- Remote Back Focus Control with One-Push AF (Autofocus) and manual fine-tuning via web browser
- Resolution: SD (up to D1), HD (720p, 1080p, 2MP, 3MP, 4MP, 5MP)
- Video compression: H.264, MJPEG
- Frame rate up to 30 fps
- Simultaneous Dual- or Tri-Streaming
- Automatic White Balance (ATW, One-Push AWB)
- Automatic Gain Control (AGC)
- Automatic Electronic Shutter (AES)
- Comprehensive set of image optimization functions like brightness, contrast, saturation and sharpness
- 3D Digital Noise Reduction (3D DNR)
- Three different exposure metering modes: average metering (light information from entire scene), centre-weighted average metering and spot metering
- Privacy Zone Masking (hiding/masking of protected areas)
- Flip function (horizontal, vertical or both)
- Digital Image Shift<sup>2)</sup>
- Motion detection<sup>3)</sup> with selectable sensitivity
- Alarm notification via DaVid Protocol<sup>3)</sup>, e-mail and FTP image upload
- Local video memory: SDHC card slot integrated<sup>3)</sup>
- Analogue video preview output (CVBS)
- Audio OUT<sup>4)</sup> / Microphone IN<sup>4)</sup>
- Voltage supply with 12V DC or via PoE (Class 0, IEEE 802.3af)
- Low power consumption (max. 4.5 W)
- 3-axis adjustment
- Two available mounting variants: in-ceiling mount (IM) or surface mount (SM)
- Available with different lens types
- Compact vandal-resistant (IK10) housing
- IP67 (surface mount variant)
- ONVIF compliant
- DIN EN 50130-4 compliant

1) ICR = IR Cut Filter Removable

2) Provides digital fine alignment of the image section (only applicable at resolutions less than 5 MP)

3) Function in preparation





4) Audio IN/OUT Y-Cable Connector FGA-30 required (optionally available)

# DDF4920HDV-DN

HD Dome Camera, 5-Megapixel, Full High-Definition, 1080p/30, H.264, Day/Night (ICR), Remote Back Focus Control with One-Push Autofocus, PoE (Class 0), Vandal-resistant (IK10)

## Variants/Accessories

Variants	
004486.403	<b>DDF4920HDV-DN-IM</b> HD dome camera, 5-megapixel, Full High-Definition, 1080p/30, H.264, Day/Night (ICR), Remote Back Focus Control with One-Push AF, PoE (Class 0), vandal-resistant (IK10), in-ceiling mount variant, F1.8 / 1.8–3 mm
004487.403	<b>DDF4920HDV-DN-SM</b> HD dome camera, 5-megapixel, Full High-Definition, 1080p/30, H.264, Day/Night (ICR), Remote Back Focus Control with One-Push AF, PoE (Class 0), vandal-resistant (IK10), surface mount variant, F1.8 / 1.8–3 mm
004486.404	<b>DDF4920HDV-DN-IM</b> HD dome camera, 5-megapixel, Full High-Definition, 1080p/30, H.264, Day/Night (ICR), Remote Back Focus Control with One-Push AF, PoE (Class 0), vandal-resistant (IK10), in-ceiling mount variant, F1.5 / 9–40 mm
004487.404	<b>DDF4920HDV-DN-SM</b> HD dome camera, 5-megapixel, Full High-Definition, 1080p/30, H.264, Day/Night (ICR), Remote Back Focus Control with One-Push AF, PoE (Class 0), vandal-resistant (IK10), surface mount variant, F1.5 / 9–40 mm
004486.405	<b>DDF4920HDV-DN-IM</b> HD dome camera, 5-megapixel, Full High-Definition, 1080p/30, H.264, Day/Night (ICR), Remote Back Focus Control with One-Push AF, PoE (Class 0), vandal-resistant (IK10), in-ceiling mount variant, F1.8 / 3.9–10 mm
004487.405	<b>DDF4920HDV-DN-SM</b> HD dome camera, 5-megapixel, Full High-Definition, 1080p/30, H.264, Day/Night (ICR), Remote Back Focus Control with One-Push AF, PoE (Class 0), vandal-resistant (IK10), surface mount variant, F1.8 / 3.9–10 mm

Accessories	
001044	 <p><b>Tinted Bubble</b> For in-ceiling and surface mount variant, 4.5"</p>
001431	 <p><b>EvC-1</b> High-Speed Ethernet data transmission via coaxial cable</p>
001678	 <p><b>Power Supply Unit (110–240 V AC -&gt; 12 V DC)</b> Universal power supply, 110–240 V AC to 12 V DC, 850 mA, plug adapter EU/UK/US/AUS</p>
003694	 <p><b>Audio IN/OUT Y-Cable Connector FGA-30</b> 3.5 mm stereo plug to 2× RCA jack incl. galvanic isolation</p>

# DDF4920HDV-DN

HD Dome Camera, 5-Megapixel, Full High-Definition, 1080p/30, H.264, Day/Night (ICR), Remote Back Focus Control with One-Push Autofocus, PoE (Class 0), Vandal-resistant (IK10)

## Specifications

### Sensor

Type	1/2.5" 5-megapixel CMOS image sensor
Signal processing	Pure Digital Signal Processing
Image capture	Progressive Scan
Minimum illumination	0,3 lux (F1.0, 50 IRE)
Dynamic range	Max. 70 dB <sup>6)</sup>

### Functions

Day/Night switching	Yes, using ambient light sensing and ICR <sup>5)</sup> function (switching threshold level adjustable)
B/W (black-and-white) mode	Automatic <sup>7)</sup> (in Night mode)
Automatic Electronic Shutter (AES)	1/25(30)–1/2500 s (Auto Slow Shutter extends maximum exposure time to 1/4(5)s with AE Preset "Low light")
3D Digital Noise Reduction (3D DNR)	On/Off
Automatic Exposure (AE) Presets	Outdoor, Indoor, Low light
Exposure metering mode	Average metering (light information from entire scene), centre-weighted average metering, spot metering
Brightness adjustment	Automatic (ALC)/Manual
Gain control	Automatic (AGC)
White balance	ATW (Auto Tracking White Balance) One-Push AWB (Automatic White Balance) MWB (Manual White Balance)
Privacy Zone Masking	Yes (max. 20% of the entire image)
Flip function	Horizontal, vertical or both
Remote Back Focus Control	Yes, One-Push AF (Autofocus) and manual fine-tuning via web browser
Digital Image Shift <sup>8)</sup>	Yes
Motion detection <sup>9)</sup> (VMD)	With selectable sensitivity (5 levels)
Alarm notification	Via DaVid Protocol (Dallmeier Video Protocol) to PGuard advance <sup>9)</sup> , e-mail, FTP image upload
Configuration	Via web browser
Languages	German, English, Spanish, French, Italian

### Lens

Mount	CS-mount
Auto iris control	Compatible with DC drive auto iris lenses
Type	<i>Specifications and available angles of view depending on variant (see "Lens Types" on page 5)</i>

### Format and Encoding

Video standard	SDTV (PAL/NTSC), HDTV (SMPTE 296M, SMPTE 274M)
Resolution	Encoder 1: 4CIF (704 × 576) / 4SIF (704 × 480) D1 PAL (720 × 576) / D1 NTSC (720 × 480) 720p (1280 × 720) 1080p (1920 × 1080) 2 MP (1600 × 1200) 3 MP (2048 × 1536) 4 MP (2336 × 1744) 5 MP (2592 × 1920) Encoder 2: Wide-CIF (480 × 288 / 384 × 288) VGA (640 × 352 / 640 × 480) 4 MP (2336 × 1744) Encoder 3: 192 × 128
Video compression	H.264, MJPEG
Audio compression	G.711
Frame rate	Up to 30 fps with 4SIF Up to 30 fps with D1 Up to 30 fps with 720p Up to 30 fps with 1080p Up to 30 fps with 2MP Up to 15 fps with 3MP Up to 12.5 fps with 4MP Up to 10 fps with 5MP
Video bit rate	0.25–10 Mbps, CBR (constant bit rate) or VBR (variable bit rate)
Audio bit rate	64 kbps
Video streaming	Simultaneous Dual- or Tri-Streaming (number of simultaneous streams depends on compression method, resolution and bit rate)
Transfer format	Progressive (full image)
Live streaming transmission method	Unicast, Multicast

5) ICR = IR Cut Filter Removable

6) According to the sensor manufacturer's specifications

7) Without colour information, or rather in black-and-white mode, the image quality in low light conditions will be much clearer (e.g. less colour noise).

8) Provides digital fine alignment of the image section (only applicable at resolutions less than 5MP)

9) Function in preparation

# DDF4920HDV-DN

HD Dome Camera, 5-Megapixel, Full High-Definition, 1080p/30, H.264, Day/Night (ICR), Remote Back Focus Control with One-Push Autofocus, PoE (Class 0), Vandal-resistant (IK10)

## Specifications (Continuation)

### Protocols

Ethernet protocols IPv4, TCP, UDP, ARP, ICMP, DHCP, NTP, HTTP, RTSP, IGMP V2, FTP, SMTP, RTP, RTCP  
 SNMP support Yes

### Connections

Analogue video preview output 1× BNC (CVBS) – for local installation only, e.g. for adjusting the focal length and image section  
 Audio OUT (Mono) / Microphone IN (Mono) 1× 3.5 mm phone jack (for stereo plug)<sup>10)</sup>  
 Mic IN: max. 63 mV (RMS), input resistance 10 kOhm, internal gain 20 dB  
 Ethernet 1× RJ45, 10BASE-T-/100BASE-TX-PoE  
 Power IN 12V DC (Weidmüller male connector SL 3.50/02/90G)

### Miscellaneous

Ambient light sensor Integrated  
 Local video memory SDHC card slot integrated<sup>11)</sup>  
 Programming interface Open platform for integration into 3<sup>rd</sup> party systems using API and ActiveX\*  
 ONVIF compliance Core Specifications 1.01 & 1.02

### Electrical Data

Voltage supply 12V DC ±10% or PoE (Class 0)  
 PoE standard IEEE 802.3af  
 Power consumption Max. 4.5 W

### Mechanical Data

Dimensions In-ceiling mount variant: approx. Ø 170 × H 135 mm (Ø 6.7 × H 5.3 inches)  
 Surface mount variant: approx. Ø 153 × H 135 mm (Ø 6.0 × H 5.3 inches)  
 Weight In-ceiling mount variant: approx. 1200 g (2.6 lb)  
 Surface mount variant: approx. 1100 g (2.4 lb)  
 Adjustment 3-axis  
 Colour White (standard variant)  
 Bubble Clear (with black inner liner for discrete surveillance)  
 Vandal-resistant Yes  
 IK protection IK10 protection against external mechanical impacts (up to 20 joules)  
 IP rating IP67 (surface mount variant only)

### Environmental Conditions

Operating temperature In-ceiling mount variant (indoor): -20°C to +40°C (-4°F to 104°F)  
 Surface mount variant (in- and outdoor): -20°C to +50°C (-4°F to 122°F)  
 Relative humidity 0%–90% RH, non-condensing

### Approvals/Certifications

Type CE, FCC, ACA, UVV "Kassen" (DGVU Test), UL, DIN EN 50130-4 compliant

10) Audio IN/OUT Y-Cable Connector FGA-30 required (optionally available)  
 11) Function in preparation

All trademarks identified by ® are registered trademarks of Dallmeier electronic.  
 All trademarks identified by \* are trademarks or registered trademarks of the following owners: ActiveX of Microsoft Corporation headquartered in Redmond, Washington, USA

# DDF4920HDV-DN

HD Dome Camera, 5-Megapixel, Full High-Definition, 1080p/30, H.264, Day/Night (ICR), Remote Back Focus Control with One-Push Autofocus, PoE (Class 0), Vandal-resistant (IK10)

## Lens Types

Lens F1.8 / 3.9–10 mm	
Type	5-Megapixel varifocal lens
Format	1/2"
Mount	CS-mount
Focal length	3.9–10 mm
Iris range	F1.8–360
Iris control	DC auto iris
Zoom	Manual
Focus	Manual
MOD (Minimum Object Distance)	0.3 m
IR corrected	Yes
Available angles of view <sup>12)</sup> (H×V) at wide end	approx. 48° × 37° with 4SIF approx. 48° × 37° with 4CIF approx. 40° × 31° with D1 NTSC approx. 40° × 31° with D1 PAL approx. 54° × 29° with 720p approx. 54° × 29° with 1080p approx. 44° × 33° with 2MP approx. 57° × 43° with 3MP approx. 66° × 48° with 4MP approx. 73° × 53° with 5MP
Available angles of view <sup>12)</sup> (H×V) at tele end	approx. 20° × 15° with 4SIF approx. 20° × 15° with 4CIF approx. 18° × 14° with D1 NTSC approx. 18° × 14° with D1 PAL approx. 23° × 13° with 720p approx. 23° × 13° with 1080p approx. 20° × 15° with 2MP approx. 25° × 19° with 3MP approx. 28° × 21° with 4MP approx. 31° × 23° with 5MP

Ultra Wide-Angle Lens F1.8 / 1.8–3 mm	
Type	5-Megapixel varifocal lens
Format	1/2.5"
Mount	CS-mount
Focal length	1.8–3 mm
Iris range	F1.8–Closed
Iris control	DC auto iris
Zoom	Manual
Focus	Manual
MOD (Minimum Object Distance)	0.5 m
IR corrected	Yes
Available angles of view <sup>12)</sup> (H×V) at wide end	approx. 88° × 72° with 4SIF approx. 88° × 72° with 4CIF approx. 74° × 62° with D1 NTSC approx. 74° × 62° with D1 PAL approx. 91° × 59° with 720p approx. 91° × 59° with 1080p approx. 84° × 64° with 2MP approx. 94° × 78° with 3MP approx. 102° × 85° with 4MP approx. 107° × 90° with 5MP
Available angles of view <sup>12)</sup> (H×V) at tele end	approx. 60° × 47° with 4SIF approx. 60° × 47° with 4CIF approx. 58° × 44° with D1 NTSC approx. 58° × 44° with D1 PAL approx. 67° × 41° with 720p approx. 67° × 41° with 1080p approx. 58° × 45° with 2MP approx. 71° × 56° with 3MP approx. 78° × 62° with 4MP approx. 84° × 67° with 5MP

Telephoto Lens F1.5 / 9–40 mm	
Type	5-Megapixel varifocal lens
Format	1/2.5"
Mount	CS-mount
Focal length	9–40 mm
Iris range	F1.5–Closed
Iris control	DC auto iris
Zoom	Manual
Focus	Manual
MOD (Minimum Object Distance)	2.0 m
IR corrected	Yes
Available angles of view <sup>12)</sup> (H×V) at wide end	approx. 22° × 16° with 4SIF approx. 22° × 16° with 4CIF approx. 18° × 14° with D1 NTSC approx. 18° × 14° with D1 PAL approx. 24° × 13° with 720p approx. 24° × 13° with 1080p approx. 20° × 15° with 2MP approx. 26° × 19° with 3MP approx. 29° × 22° with 4MP approx. 33° × 24° with 5MP
Available angles of view <sup>12)</sup> (H×V) at tele end	approx. 5° × 3° with 4SIF approx. 5° × 3° with 4CIF approx. 5° × 4° with D1 NTSC approx. 5° × 4° with D1 PAL approx. 6° × 3° with 720p approx. 6° × 3° with 1080p approx. 5° × 4° with 2MP approx. 7° × 5° with 3MP approx. 8° × 6° with 4MP approx. 9° × 6° with 5MP

12) All specifications ±5%. Minor deviations with lenses may be a result of manufacturing tolerances and do not constitute a defect.

All trademarks identified by ® are registered trademarks of Dallmeier electronic.

All trademarks identified by \* are trademarks or registered trademarks of the following owners: ActiveX of Microsoft Corporation headquartered in Redmond, Washington, USA

# DDF4920HDV-DN

HD Dome Camera, 5-Megapixel, Full High-Definition, 1080p/30, H.264, Day/Night (ICR), Remote Back Focus Control with One-Push Autofocus, PoE (Class 0), Vandal-resistant (IK10)

## Dimensions

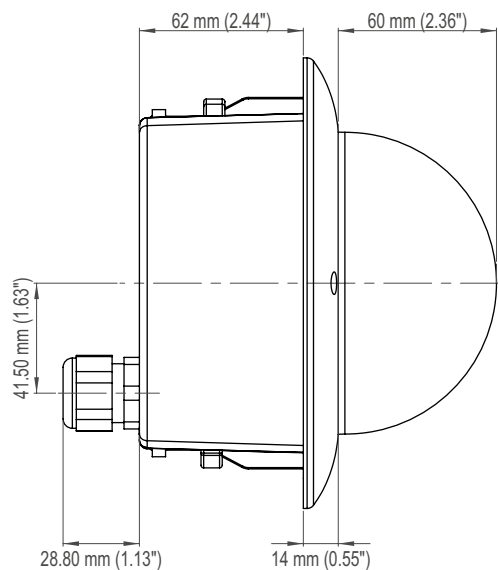
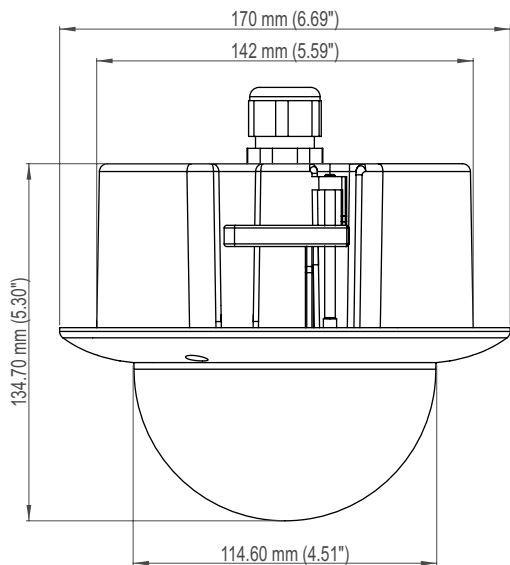

In-ceiling mount variant

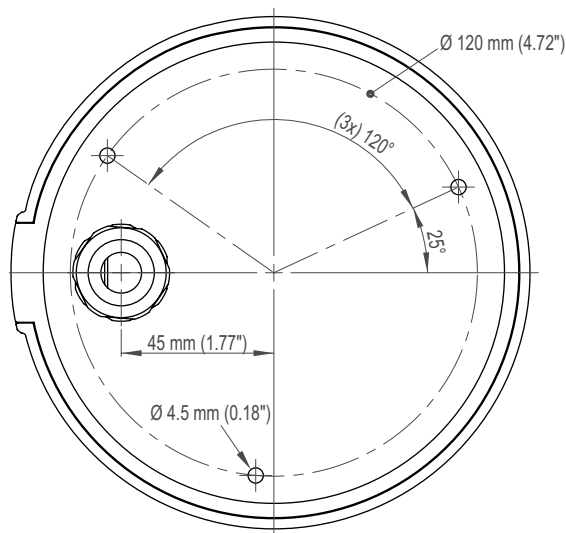
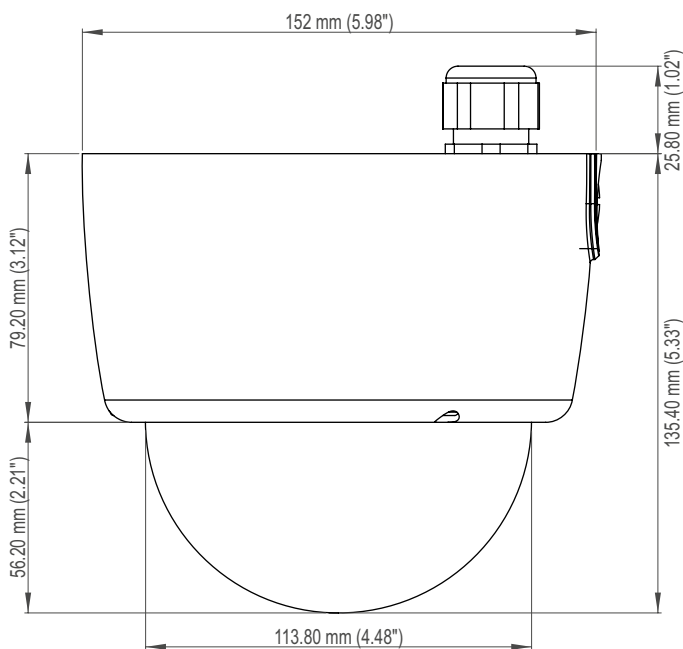

Surface mount variant