

HGV

EXTRA LARGE-SIZED CAMERA HOUSING

MAIN FEATURES

- Extra-large dimensions to fit the largest motorised zoom lenses
- Base constructed from aluminium and top part of the body in robust ABS material
- IP66/IP67
- Removable top body with safety cord
- Equipped as standard with camera power supply, reinforced triple heater with two continuous duty fans, wiper

DESCRIPTION

The HGV housing is ideal for outdoor monitoring of great distances for applications in public safety, environmental monitoring and border surveillance or at harbours, along coastlines and at airports.

Robust aluminium housing designed to simplify the installation and service, and guarantee total protection against all environmental conditions.

The big dimensions of this camera housing make it suitable to contain the largest zoom lenses of the market.

For easy access during the installation and the adjustment of the camera, it is possible to remove the upper part of the housing body, which is held by a robust safety cord.



HGV



HGV

HGV - TESTED OPTICS		
	Model Number	Zoom
FUJINON	C22x17B-S41	22x
FUJINON	D60x12.5	60x
COMPUTAR	H30Z1015 series	30x
TOKINA	TM55Z1038 series	55x
ERNITEC	Q10Z25SPNA	25x
ERNITEC	Q30Z25SPNA	25x
PENTAX	H15Z/TS15Z	15x
PENTAX	H18Z	18x
PENTAX	H20Z/TS20Z	20x
PENTAX	H55Z	55x

TECHNICAL DATA

GENERAL

Base in aluminium, epoxy polyester powder painting, RAL9002 colour
Upper body and sunshield in ABS
Stainless steel external screws

MECHANICAL

Plate with 4xM16 cable glands (in addition a stainless steel plate is supplied for customized drilling)
Glass window: See drawing
Internal usable area: See drawing
Unit weight: 9.2kg (20.3lb)

ELECTRICAL

Integrated wiper

- IN 230Vac, consumption 7W max
- IN 24Vac, consumption 7W max

Heater (Ton 15°C±3°C (59°F±5°F), Toff 22°C±3°C (72°F±5°F))

- IN 120/230Vac, fan assisted triple heater, consumption 150W
- IN 24Vac, fan assisted triple heater, consumption 80W

Camera power supply

- IN 100-240Vac, 50/60Hz - OUT 12Vdc, 1.25A (built-in for version 230Vac)

ENVIRONMENT

For installation indoors and outdoors
Operating temperature with heating: from -20°C (-4°F) up to +60°C (140°F)

CERTIFICATIONS

Electrical safety (CE): EN60950-1
Electromagnetic compatibility (CE): EN50130-4, EN61000-6-3
IP protection degree: EN60529 (IP66/IP67, with cable glands)
EAC certification

ACCESSORIES

WASOV5L5M00	Water tank 5l (1 gal), pump with delivery up to 5m (16ft), IN 230Vac-24Vac-120Vac
WASOV23L5M00	Water tank 23l (6 gal), pump with delivery up to 5m (16ft), IN 230Vac-24Vac-120Vac
WASOV23L11M00	Water tank 23l (6 gal), pump with delivery up to 11m (36ft), IN 230Vac-24Vac-120Vac
WAS1V23L30M00	Water tank 23l (6 gal), pump with delivery up to 30m (98ft) with water floating, IN 230Vac
WAS3V23L30M00	Water tank 23l (6 gal), pump with delivery up to 30m (98ft) with water floating, IN 120Vac
WASPTOV5L5M00	Water tank 5l (1 gal), pump with delivery up to 5m (16ft), IN 230Vac-24Vac-120Vac
WASPTOV23L5M00	Water tank 23l (6 gal), pump with delivery up to 5m (16ft), IN 230Vac-24Vac-120Vac
WASPTOV23L11M00	Water tank 23l (6 gal), pump with delivery up to 11m (36ft) with water floating, IN 230Vac-24Vac-120Vac
WASPT1V23L30M00	Water tank 23l (6 gal), pump with delivery up to 30m (98ft) with water floating, IN 230Vac
WASPT3V23L30M00	Water tank 23l (6 gal), pump with delivery up to 30m (98ft) with water floating, IN 120Vac
DTWRX	Data receiver for remote control of the wiper and WASPT range pumps in stand-alone housings

BRACKETS AND ADAPTORS

WBLA	Bracket and ball joint in solid anticorrosion aluminium construction, RAL9002
------	---

PACKAGE

Model Number	Weight	Dimensions (WxHxL)	Master carton
HGV52K1A100	-	-	-

AVAILABLE MODELS

Model Number	Sunshield	Power supply 230Vac, 50/60Hz	Power supply 24Vac, 50/60Hz	Power supply IN100-240Vac, 50/60Hz - OUT 12Vdc, 1A	Triple fan-assisted heating 24Vac	Triple fan-assisted heating 120/230Vac	Wiper kit 230Vac	Wiper kit 24Vac
HGV52K1A100	✓	✓	-	✓	-	✓	✓	-
HGV52K2A200	✓	-	✓	-	✓	-	-	✓

TECHNICAL DRAWINGS

The dimensions of the drawings are in millimetres.

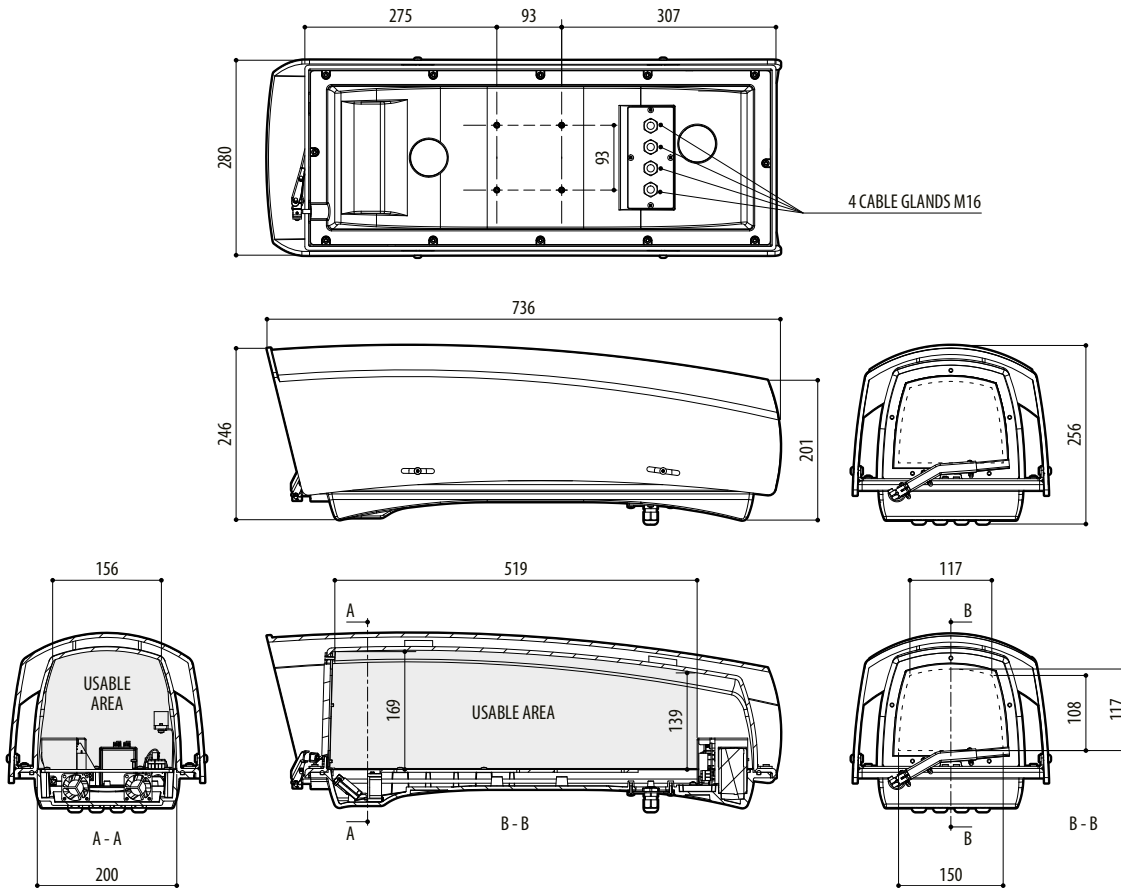

HGV